

FLAMESHIELD 8524 FIRE CURTAIN MAX SYSTEM HEADBOX CONFIGURATION SECTIONS - STANDARD AND SMOKE SEALS

FLAMESHIELD MAX
STANDARD 254 x 300mm

PRODUCT	MAX WIDTH (C)	MAX DROP (D)	FABRIC
FC	10000	5000	A1 STD

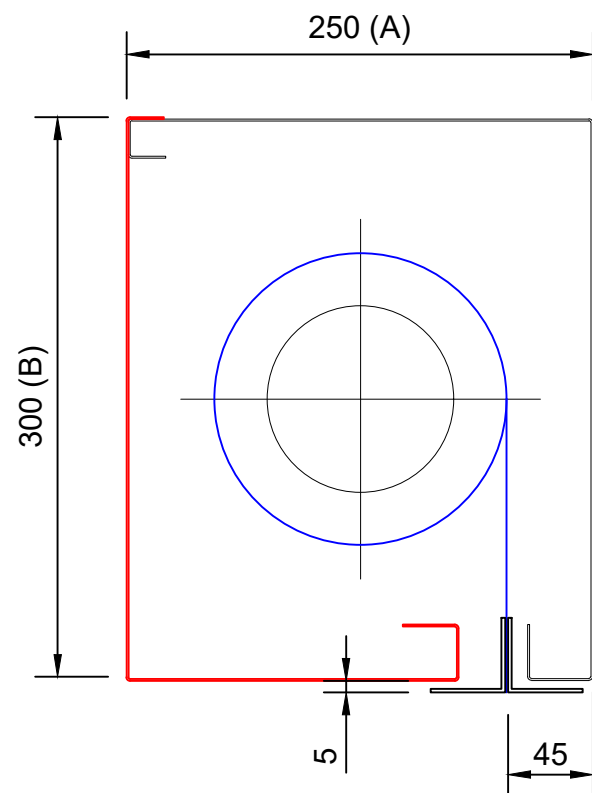

FLAMESHIELD MAX SS
STANDARD 254 x 300mm

PRODUCT	MAX WIDTH (C)	MAX DROP (D)	FABRIC
FC	10000	5000	A1 STD

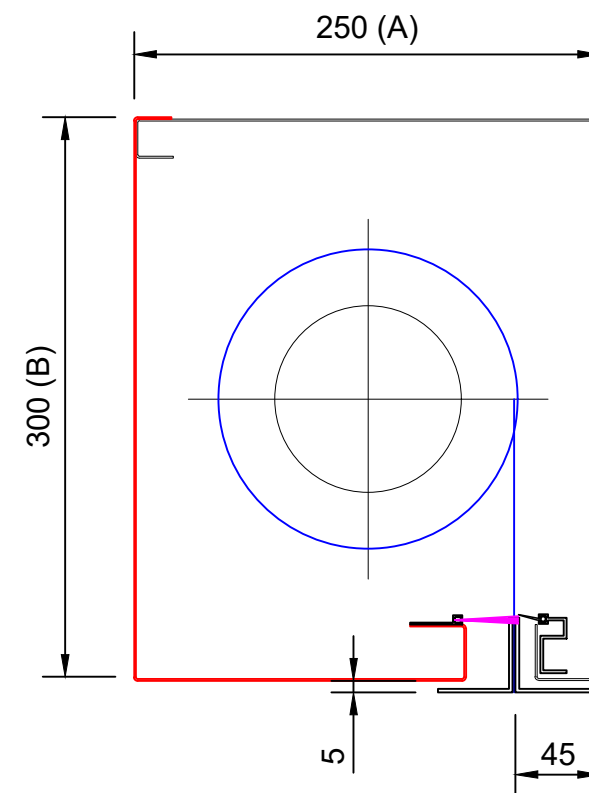

* ADITIONAL SIZES AVAILABLE SUBJECT TO ASSESMENT
* ADDITIONAL ASSESSMENT IS REQUIRED FOR DROP LENGTH OVER 5000mm

Drawing Title: FLAMESHIELD FIRE CURTAIN BS 8524 MAX/S	Drawn By: DD
	Date: 22-10-2024
	Checked By: CE
	Date: 22-10-2024
All dimensions in millimetres - DO NOT SCALE	Drawing No: CD02MF_01



A1 Shutters Limited
Jackson Works
Raikes Lane Industrial Estate
Bolton BL3 2NH
Telephone 01204 383839

FLAMESHIELD BS8524 MAX / S FIRE CURTAIN GENERAL ARRANGEMENT DRAWING: FACE FIT

Key:
— Components supplied by A1S Group
— Structure already in situ / or required by others

All openings must be capable of carrying the weight of the fire curtain and be equal or greater than the fire resistance of the fire curtain assembly.

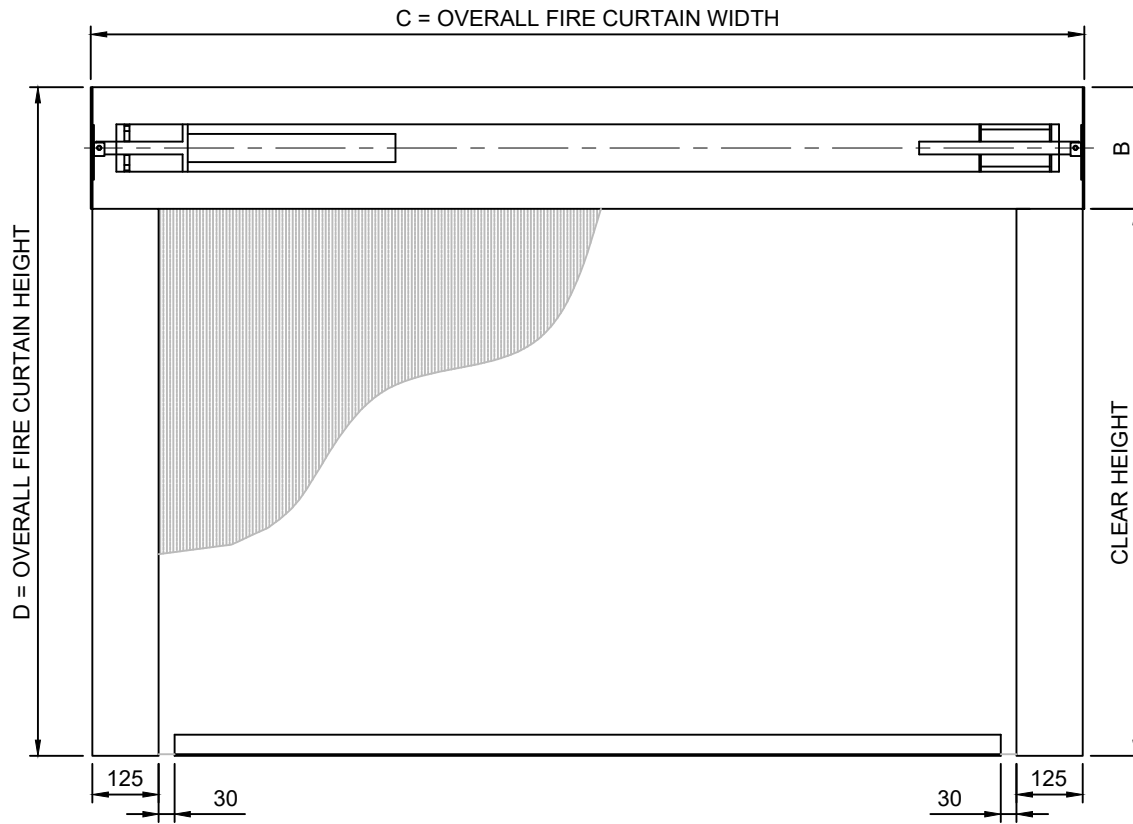

CD02MF

Full width removable hood (Red) must be accessible for maintenance purposes

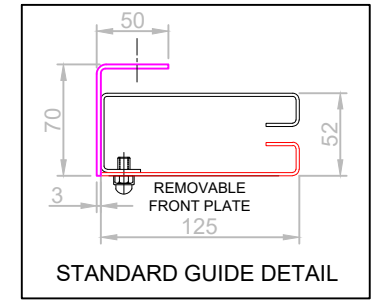
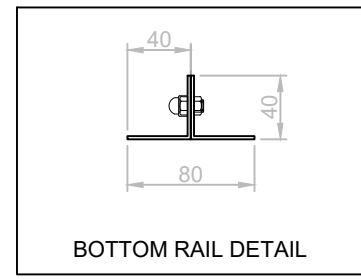
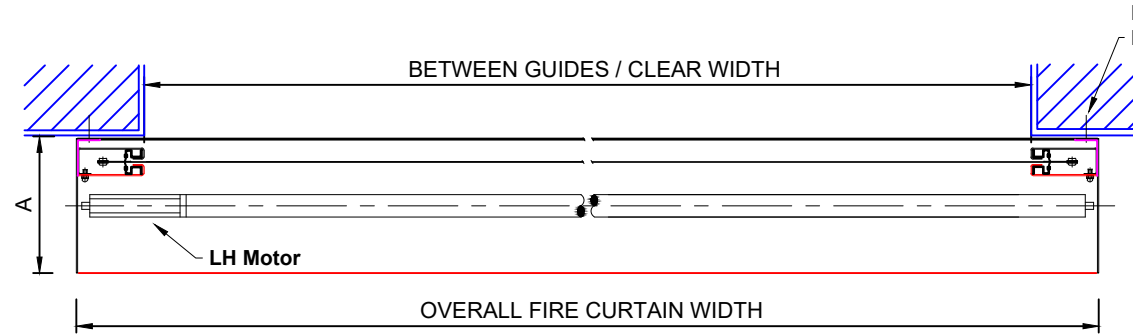
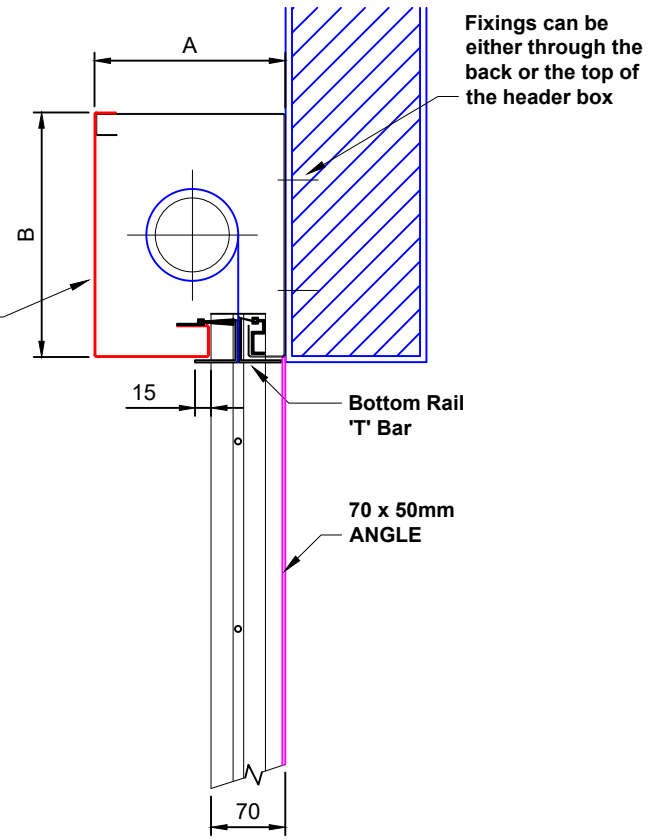

Drawing Title: FLAMESHIELD FIRE CURTAIN BS 8524 MAX/S	Drawn By: DD
	Date: 22-10-2024
	Checked By: CE
	Date: 22-10-2024
All dimensions in millimetres - DO NOT SCALE	Drawing No: CD02MF-02



A1 Shutters Limited
 Jackson Works
 Raikes Lane Industrial Estate
 Bolton BL3 2NH
 Telephone 01204 383839

* ADDITIONAL SIZES AVAILABLE SUBJECT TO ASSESSMENT